

For offshore and marine ventilation systems



**MATERIALS**

PART	MATERIAL	FINISHING
Frame	Carbon steel	Painted or galvanised
Frame	Stainless steel EN 1.4301 (AISI304), EN 1.4404 (AISI316L)	-
Blades	Steel	Galvanised
Blades	Stainless steel EN 1.4301 (AISI304), EN 1.4404 (AISI316L)	-
Maintenance-free bearings	Stainless steel EN 1.4404 (AISI316L)	-
Shafts	Stainless steel EN 1.4404 (AISI316L)	-

**BLD PRODUCT OPTIONS**

- Models for horizontal and vertical installation available
- Circular connection pieces are available
- Standard construction places weights on the right hand side. Weights on the left hand side available as an option

**APPLICATIONS**

Halton BLD non-return dampers are used in offshore and marine applications to prevent backflow through ventilation ductwork system. The BLD dampers do not need an actuator or motor. Non-return dampers can be installed in rectangular or circular ducts, horizontally or vertically. If required, they can easily be set by adjusting the weight of each damper/installation. When the blades are in the open position, the device does not cause significant pressure loss, noise or flow disturbance.

**FEATURES**

- Fixed frame in painted, galvanized or stainless steel. Blades of galvanized or stainless steel
- Models for horizontal or vertical installation
- Available as ATEX/IECEx certified
- Leakage class (EN1751:2014) of closed damper up to class 2. Details available from Halton
- Blades contain silicone seal to lower the leakage through blades
- Blades linked and open in parallel
- Adjustable by changing the position of counterweights. Standard construction places weights on the right hand side, weights on the left hand side available as an option
- Maximum duct pressure for damper construction 5000 Pa and maximum air velocity 15 m/s. In case of high duct pressure, contact Halton for finding the most suitable solution
- Temperature operation range up to +100°C, optionally up to +180°C

**GENERAL BLD DRAWINGS**

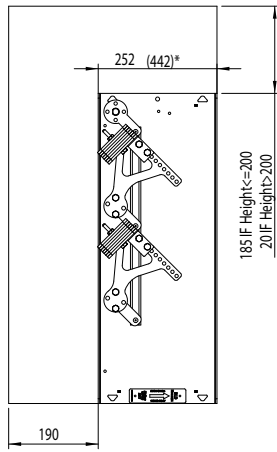

\*THIS DIMENSION AS OPTION WHEN ACTUATING MECHANISM NEEDS TO BE INSIDE DAMPER DEPTH

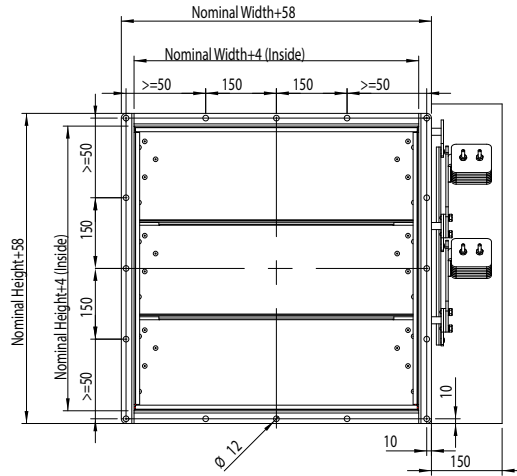

OPERATION AREA

**BLD DRAWING, CIRCULAR CONNECTIONS**

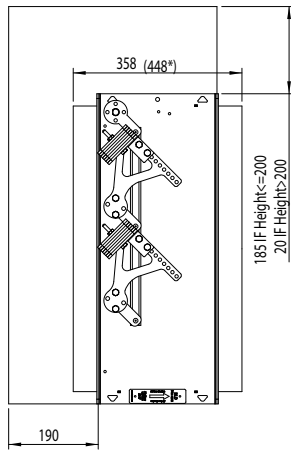

\*THIS DIMENSION AS OPTION WHEN ACTUATING MECHANISM NEEDS TO BE INSIDE DAMPER DEPTH

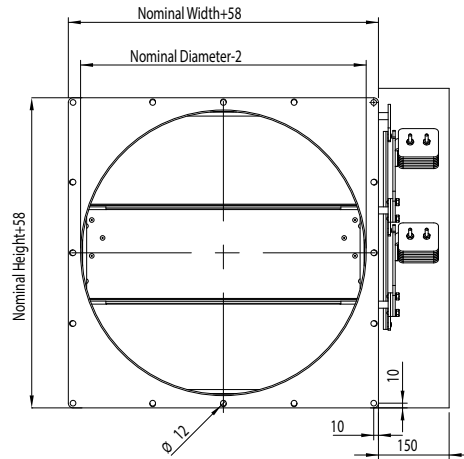

OPERATION AREA

**BLD CIRCULAR, WITH CONNECTION FLANGES**

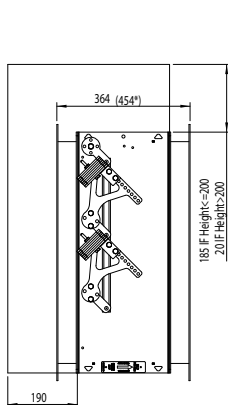

\*THIS DIMENSION AS OPTION WHEN ACTUATING MECHANISM NEEDS TO BE INSIDE DAMPER DEPTH

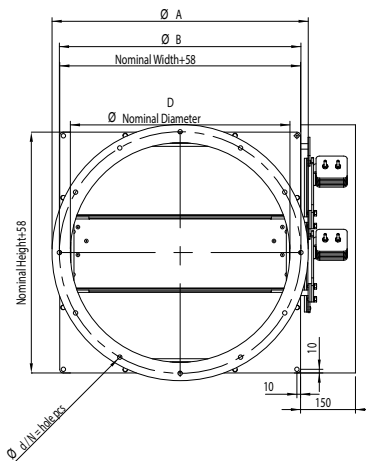

OPERATION AREA

D	B	A	d	N
200	225	300	8,5	4
250	280	350	12	4
315	355	415	12	8
400	450	500	12	8
500	560	600	12	12
630	690	730	12	12
800	860	900	12	16
1000	1070	1100	15	16
1250	1320	1350	15	20

**BLD DIMENSIONS AND MATERIAL THICKNESS**

BLD non-return dampers meet international standards for both rectangular (width B 150-1200 and height H 150-1400 mm, 1mm division) and circular ducts (Ø100 - 1250 mm). Non-standard dimensions are available on request. Standard flange width 27 mm. Flanges and drilling also available according to ISO 15138 standards. Modular construction sizes up to 2400x2800 mm. Standard frame material thickness 3 mm. Blades made of two sheets, each being 0.8 mm thick (sandwich design).

**BLD OPERATION PRINCIPLE**

Non-return damper will allow one-way airflow in the ductwork. This feature is based on imbalanced blades. When the pressure in the ductwork drops below minimum opening force required, the blades close and seal the duct to prevent backflow. The minimum opening force can be adjusted with weights. Minimum opening pressure 30 Pa.

**WEIGHTS****STANDARD HALTON BLD DAMPERS (KG) INCLUDING COUNTER WEIGHTS. FRAME THICKNESS 3 MM**

H/ HEIGHT (mm)	B / WIDTH (mm)												D2 ØD (mm)	Weight (kg)
	150	200	300	400	500	600	700	800	900	1000	1100	1200		
150	8	9	11	13	15	16	18	20	22	24	25	27	100	12
200	10	12	12	14	16	19	20	22	24	26	28	29	160	12
300	12	13	15	18	20	21	24	26	29	31	34	35	200	15
400	14	15	18	20	23	25	28	30	33	36	37	40	250	17
500	17	17	21	24	27	29	32	35	37	40	43	45	315	21
600	19	20	24	26	29	32	36	39	42	45	47	51	400	26
700	21	23	26	30	33	37	40	43	47	50	53	57	500	36
800	22	24	27	33	36	40	43	47	51	54	58	62	630	45
900	26	28	32	36	39	44	48	52	56	60	63	67	800	63
1000	28	30	34	39	43	48	51	55	60	64	68	72	1000	87
1100	31	33	38	42	47	51	56	60	65	70	72	78	1250	116
1200	33	35	40	45	50	54	59	64	69	74	78	84		
1300	36	38	44	48	53	58	64	69	74	79	83	89		
1400	38	40	46	51	56	62	67	73	78	83	88	94		

